

July 12, 2010 Seattle City Council Presentation

SR 99 Deep Bored Tunnel Design-Build Contract and Engineering Challenges

Overview

- There are inherent risks in any underground construction, including tunneling, due to subsurface uncertainty. Tunneling has gained favor due to generally lower risks than large excavations and greatly reduced surface disturbance, particularly in urban areas.
- When things go seriously wrong with urban tunnels, the consequences can be significant, leading to long delays, large cost overruns, and extensive 3rd party damages.
- Today's presentation focuses on the significant tunneling risks because it is important the Council, as well as the public, have a realistic understanding of these risks.
- WSDOT is doing the right things to address and manage these risks. WSDOT has assembled a strong team, combining their experienced staff with external tunnel and risk experts, and the design-build process provides the opportunity for this team to work together with the selected Design-Build (DB) contractor team giving the project the best chance for success.

SR 99 Tunnel Challenges

- The SR 99 Bored Tunnel will require use of the largest diameter Tunnel Boring Machines (TBMs) manufactured to date – being at the leading edge can be risky. The state of the art in soft ground TBMs has advanced significantly over the last 30 years. Successful tunnel projects have gone from 48' (1994) to 50' (2008) to 51' (2010 in construction). SR 99 will be ~ 54' and there are 62' tunnels being planned in Russia. The diameter of TBMs has increased incrementally a few feet at a time; each increment builds knowledge. New lessons will be learned on the SR 99 Bored Tunnel.
- It is also important to understand that larger diameter TBMs have some significant advantages. There is plenty of interior room for equipment and systems to better manage mining and provide safe access for maintenance and repairs. Potential boulder impacts are significantly reduced. There is evidence to indicate these advantages allow better control of settlement under routine tunneling operations.
- The SR 99 Bored Tunnel will pass through a dense urban setting making the consequences of TBM problems or failure more significant both in terms of delays and costs for repair and potential for 3rd party impacts.
- The SR 99 Bored Tunnel is a 'Soft Ground' tunnel meaning that the hole bored by the TBM will not be self supporting (like a tunnel in rock); the ground will move into the excavation if not continuously supported. The soils to be mined are highly variable; however, soft ground is a relative term – the tunnel will be driven through dense soils that have been compacted by 3,000 ft of glacial ice. There are looser, weaker soils and clean sands above the tunnel, particularly for the first 1,500 feet, which pose more significant risks for deformation.
- Seattle area glacially consolidated soils have caused significant wear to TBM cutterheads and tools. It is not just the abrasive nature of the soil particles, but rather their presence in hard glacial till and till-like soils and the TBM forces required to mine these soils. Boulders will be present which can also damage or break the TBM cutting tools.
- What are the major risks? If the ground support pressure at the face of the TBM is not properly maintained or over mining is not quickly recognized and corrected, these conditions can lead to larger than predicted deformation and settlement, sink holes appearing at the ground surface, or even ground collapse. If not addressed through proper use of conditioners and routine maintenance, damage and wear to the TBM cutterhead and tools can require the TBM to be stopped for many months while extensive and difficult repairs are performed.

Cost Estimate and Budget

- There is a history of tunnel and bridge ‘megaprojects’ going over budget. The Flyvbjerg study found that costs for these projects were an average 34% over their allocated costs. The major factors leading to such overruns included optimistic assumptions, not accounting for project risks, not including escalation, and adding project ‘enhancements’ during the course of construction.
- WSDOT’s Cost Estimate Evaluation Process (CEVP) was specifically designed to address these factors and provide an indication of the probable range of project costs. It is widely recognized as the best practice and the resulting estimates have been shown to give a much more realistic picture of probable project costs and the potential impact of cost overruns.
- CEVP provides a range of probable project costs for the tunnel at completion. The December 2009 CEVP model indicated a 10% probability that the final project costs would be less \$1.54B and a 90% probability that they would be less than \$2.25B. The January 2010 WSDOT \$1.96B estimate for construction and other project costs is at the 60% probability level.
- Once the DB contract bids are received, the expected costs for key project elements will be known and the probable range of construction costs will be substantially reduced. The CEVP model includes all project risks; however, the DB Request for Proposals (RFP) allocates responsibility for many of these risks to the DB contractor. The DB contractor’s evaluation of its risks, given its selected means and methods to accomplish the work, will be reflected in its bid amount. The DB contractor’s bid price also has to account for cost escalation.

Unanticipated Conditions

- Unanticipated subsurface conditions (Differing Site Conditions) are the most likely source of significant change orders.
- WSDOT performed an extensive geotechnical and environmental investigation including exploration borings at typical intervals of ~400 feet or less and abundant soil and environmental testing that meets or exceeds the standard of practice for complex ground conditions. It is unlikely that additional explorations would significantly enhance understanding of subsurface conditions.
- The RFP includes a Geotechnical Baseline Report (GBR) for bid that establishes certain expectations (based on known or anticipated conditions) upon which the DB contractor has to base its bid. Examples include physical properties of soil units, the number and size of boulders, soil abrasion, tunnel face conditions, and ground stability. The baseline helps promote consistency in contractor bid assumptions and forms the basis for evaluation of differing site conditions during construction.
- The baseline puts a lot of risk on the DB contractor – stating that ‘mixed face’ conditions will be encountered everywhere and that it will be essentially impossible to predict in advance the exact thickness and lateral extent of any soil unit at any location along the alignment. The contractor’s equipment and its operation must have the flexibility to deal with this uncertainty.
- Design-build contracting provides unique opportunity to establish additional ‘baselines’ that consider the DB contractor’s selected means and methods. Numerous design decisions will be made based on assumptions about subsurface conditions and ground behavior beyond the baseline conditions defined for bid. WSDOT’s experts advised them to not prepare an additional GBR for construction. However, WSDOT has established various ‘task forces’ led by the DB contractor to address issues that come up in design. One function of these task forces will be to help assure consensus on such means and method baseline assumptions. We have encouraged WSDOT to formally document these consensus decisions, and proactively address any differences of opinion on the DB contractor’s design assumptions, to further mitigate the number and extent of Differing Site Condition claims.

Deformation and Settlement

- All subsurface excavations cause ground deformations that can result in settlement. Deformation during tunneling can come from both normal and 'sub-optimum' operation of the TBM. Settlement associated with normal operation results from the need to excavate a slightly larger diameter than the TBM shield in order to allow the TBM to move forward. The theoretical amount of this settlement varies up to a few inches. However, numerous factors can cause the actual amount to be more or less than predicted.
- The highest risk for settlement during 'normal' operation being greater than predicted is in the first ~1,500 feet of tunneling. Reasons include complications and intermittent mining during launch, the TBM learning curve, and the presence of loose soils and potentially flowing sands immediately above the TBM crown.
- Settlement due to 'sub-optimum' operation is caused by over excavation – the excavation of a larger volume of soil than required to advance the TBM due to inadequate pressure at the face or flowing sand entering the TBM from outside the excavated diameter. Over excavation can lead to larger than predicted ground deformations, sink holes, or ground collapse.
- There is a clear demarcation in the RFP between WSDOT and contractor responsibility. WSDOT takes responsibility for deformations that are at or slightly above the theoretical amount for a well managed normal tunneling operation; however, there are incentives for the contractor to reduce the exposure. The DB contractor is responsible if deformations exceed these limits. This places a lot of responsibility on the contractor and will necessitate ground improvements beyond those mandated by the RFP.
- The RFP includes extensive Technical Requirements for the control, monitoring, and mitigation of overexcavation by the TBM. These requirements are state of the art and take advantage of the flexibility provided by a large diameter TBM. Properly implemented, these measures will greatly mitigate the chances of sink holes or ground collapse.
- WSDOT performed thorough evaluations of ramps, structures, and utilities directly above and near the tunnel. Ground improvement consisting primarily of compaction grouting is required for all structures where the risk of settlement damage is moderate or greater. Compensation grouting has been proven to be a flexible and effective method of mitigating settlement beneath structures on numerous urban projects, including the Seattle bus tunnel construction.
- The DB contractor is required to present its approach to design, operation, and maintenance of the TBM with a focus on how it will address the anticipated ground conditions and minimize ground loss in their proposal. In the original RFP, this section was worth 10% of the technical evaluation factors. We questioned this weighting and WSDOT indicated that it had been increased to 40% by addendum.

TBM Maintenance

- Excessive wear and damage to cutterhead tools is the primary cause of slow or delayed TBM progress. If the tools become excessively worn, 'secondary' wear damage to the cutterhead itself can take place necessitating major repairs, stopping tunnel progress for weeks or months. Extended delays for repairs are very costly. Wear and cutterhead damage rarely result in abandonment of the TBM.
- Proper wear control and maintenance requires appropriate soil conditioners to reduce wear and routine maintenance to replace tools before they become too worn to protect the cutterhead. This approach has been shown to be effective for the abrasive Seattle area soils, as demonstrated on numerous local tunnel projects.
- The RFP includes extensive Technical Requirements for the use of soil conditioners, monitoring of tool wear, and routine maintenance. These requirements mitigate the risk that wear will go unnoticed or exceed maximum tolerated tool wear.
- Because the TBM will be below the groundwater table, essentially all access to the face of the TBM will require compressed air interventions. Compression and decompression for workers can significantly extend the time required for inspection and maintenance. To help assure adequate time is included in the DB contractor's bid, WSDOT has specified minimum 60 days of interventions. This is equivalent to three eight hour shifts per week or more. Additional time is allowed in the shared contingency, but at 50% of the contractor's cost and without overhead and profit.
- We inquired as to the ability of the DB contractor to put off or limit inspections and maintenance to save costs. WSDOT indicated that it has the right under the RFP to require inspection and maintenance stops and will exercise this right to help assure wear is adequately controlled. We consider this important right to be good practice.
- For both safety and control of deformation, it is important that face stability is maintained during access to the cutterhead for inspections and maintenance. The RFP Technical Requirements address ease of tool replacement and the need to maintain face stability. Given the size of the TBM and the expected mixed-face conditions, we cautioned WSDOT that air pressure alone is likely to be inadequate to provide face support and that multiple, redundant means of support should be implemented by the DB contractor. WSDOT indicated that this would be a significant factor in the evaluation of the DB contractor's technical proposal.

Construction Management

- Diligence is required in monitoring and enforcement during construction. It has been shown, in case after case, that information on developing problems was available but not understood or not evaluated in time to prevent ground or equipment failures.
- WSDOT indicated it will retain technical experts, particularly those familiar with TBM operation and maintenance, to serve as part of its construction management team. This team will be established in advance of the selection of the DB contractor and be involved in the task forces and design reviews.
- Task forces required by the RFP, including contractor, WSDOT and outside representatives, will facilitate establishment of good communications during design and help assure that good communication continues through construction. Of particular importance related to the major risks, the Construction Monitoring Task Force will meet daily during the tunnel drive to interpret and review the all TBM performance and monitoring instrumentation data and agree upon appropriate actions to be carried out during the next 24 hour period.
- WSDOT's dispute resolution process follows the best practices for underground construction. Combined with the opportunity during the design-build process to establish clear expectations and responsibilities between WSDOT and the DB contractor, the process will provide the best opportunity to address and resolve disputes before they can compound cost overruns.

Earth Pressure Balance TBM (Herrenknecht, 2010)

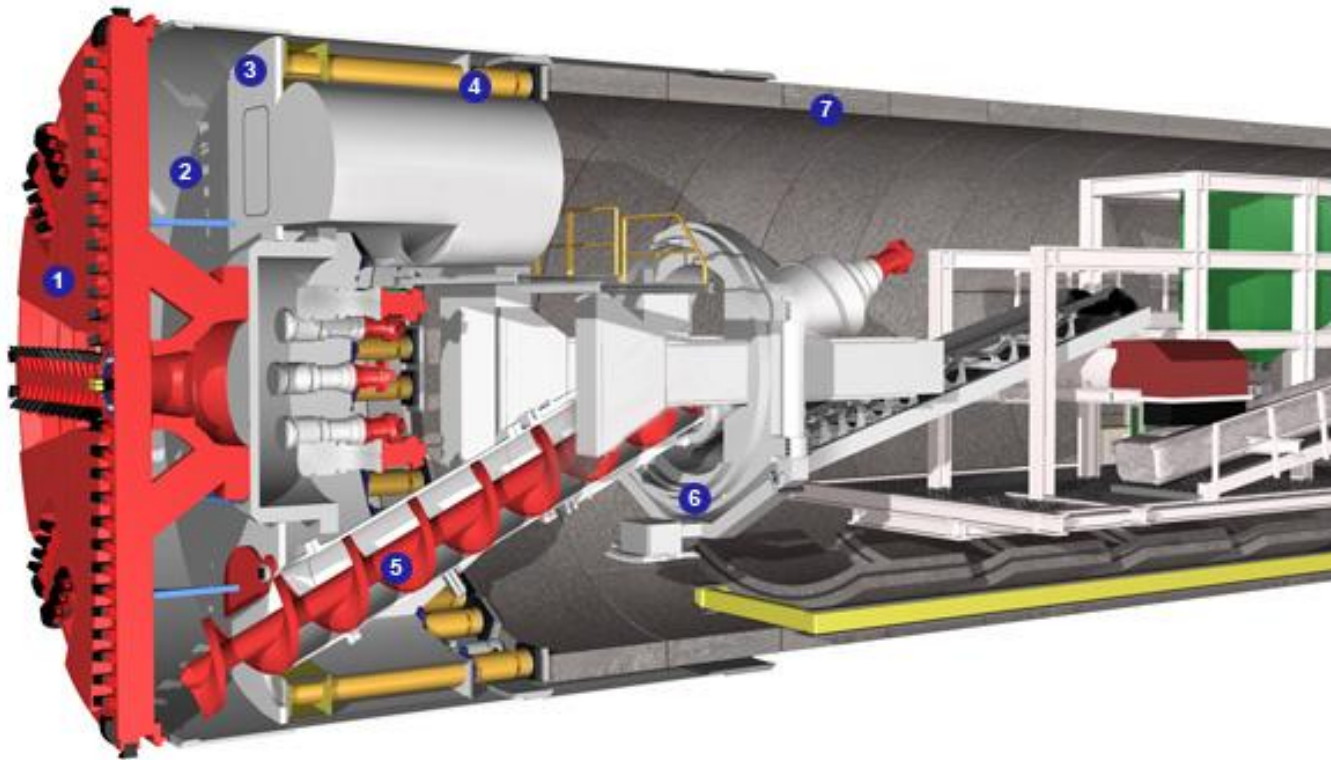

1. Cutterhead
2. Excavation Chamber
3. Bulkhead
4. Thrust Jacks
5. Conveyor Screw
6. Segment Erector
7. Segmental Lining

Slurry Pressure Balance TBM (Herrenknecht, 2010)

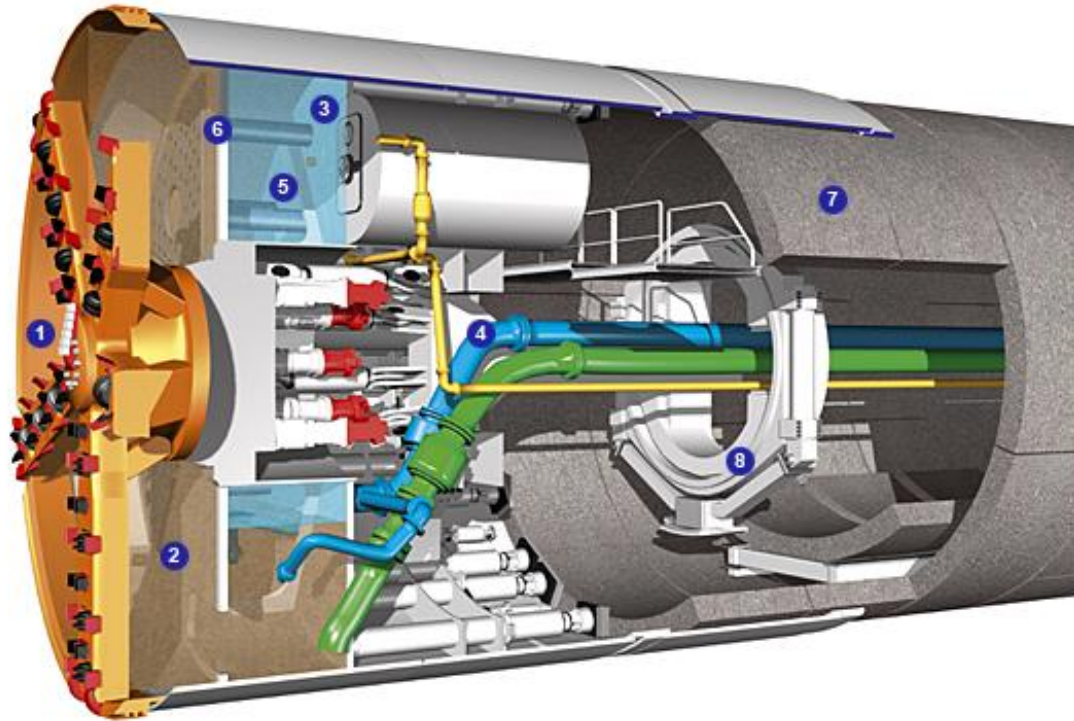

1. Cutterhead
2. Excavation Chamber
3. Bulkhead
4. Slurry Feed and Return Lines
5. Air Bubble
6. Submerged Wall
7. Segmental Lining
8. Segment Erector